

UHPPOTE

HBK-D04K

RFID CARD READER

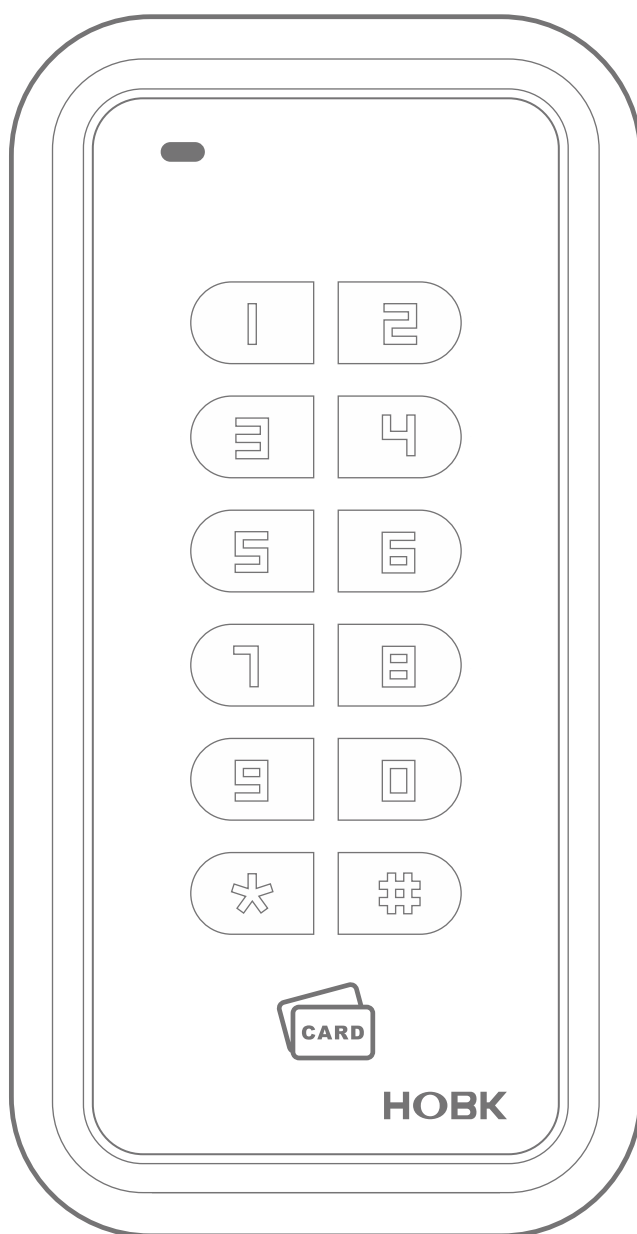

USER MANUAL

Introduction

The HBK-D04K card reader by HOBK offers Wiegand out for universal compatibility with access control system. It can't work alone and needs to work with Wiegand protocol access controller, such as access control panel, fingerprint device or master controller.

Features

- Waterproof, conforms to IP65.
- Support wiegand 26bits or wiegand 34bits output format.
- Ultra-low power consumption, the standby current is less than 50mA.
- Fast response speed, the door opening time is less than 0.3s.
- It is useful for safety door system, easy to connect and use.
- Widely used in factories, houses, residential quarters, offices, mechanical and electrical control equipment and so on.

Specification

Working Voltage	12VDC	Static Current	≤50mA
Working Humidity	10%-90%RH	Product Weight	16.79oz
Card Type	ID Card or IC Card	Waterproof Rating	IP65
Lead Cable Length	9-27/32" [250mm]	Enclosure Material	Zinc Alloy
Frequency	125KHz or 13.56MHz	Panel Material	PC Plastic
Status Indication	Bi-color LED + Buzzer	Communication Distance	<328ft
Enclosure Size	4-7/8"x2-33/64"x1-9/32" [124x64x32.4mm]		
Working Temperature	-22°F to +140°F [-30°C to +60°C]		
Output Format	Wiegand 26bits (default), Wiegand 34bits (optional)		
LED Status Indication	Red means standby, Green means activated		

Wiring Definition

Color	Functionality	Description
Red	+12V	Positive DC power lead
Black	GND	GND
Green	D0	Wiegand data zero
White	D1	Wiegand data one
Blue	LED	LED signal feedback
Yellow	BEEP	Buzzer signal feedback
Orange	Wiegand 34bits	Optional

Note: If the output format of the card reader you want is wiegand 34bits, please connect the Orange wire and the Black wire together.

Dimensions

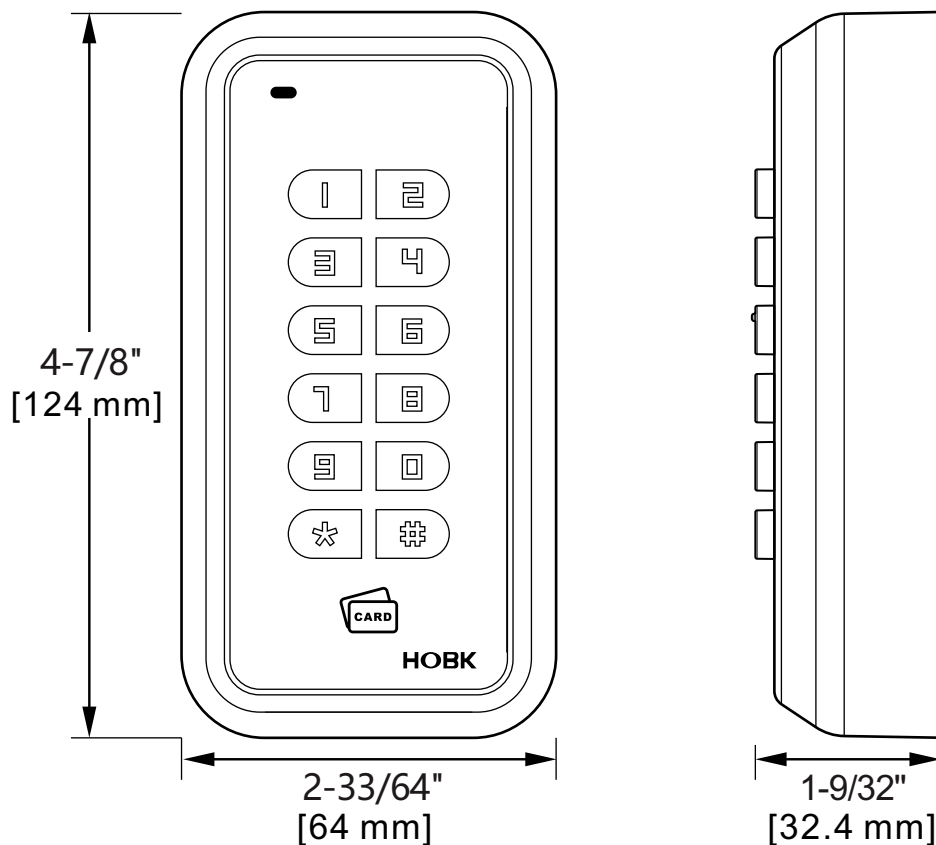

Installation

- Remove the back cover from the reader
- Drill 4 holes on the wall for the self-tapping screws and 1 hole for the cable
- Put the supplied plastic anchors into the 4 holes
- Fix the back cover firmly on the wall with 4 self-tapping screws
- Thread the cable through the cable hole
- Attach the reader to the back cover

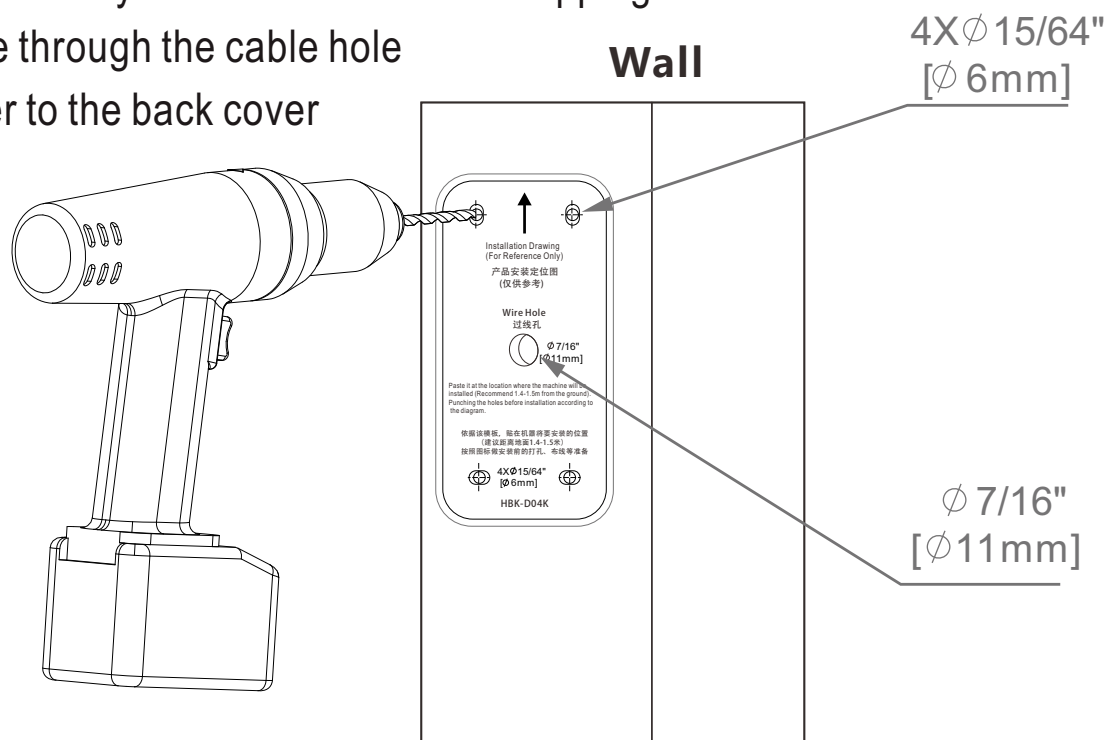

Figure 1 - Hole locations

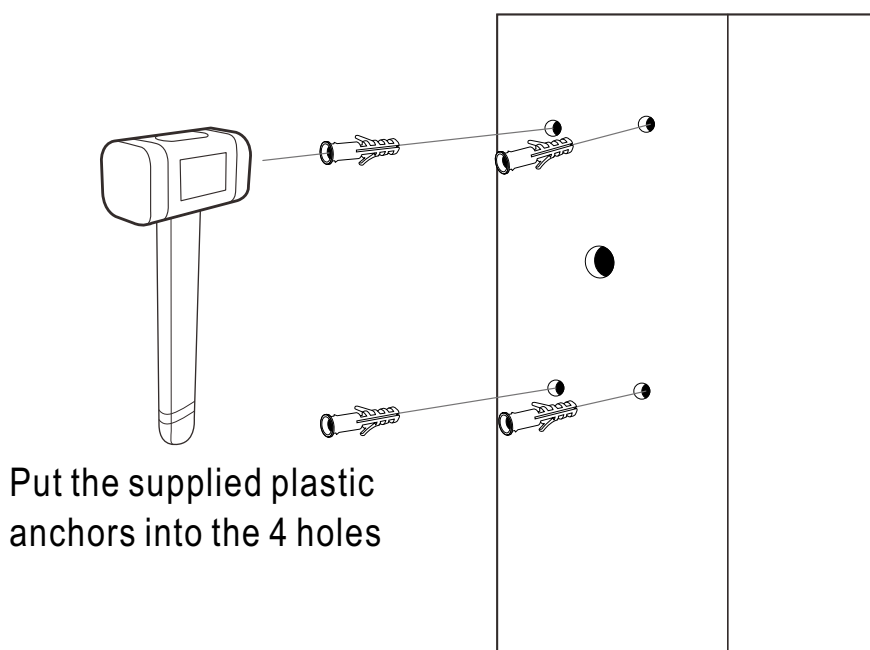

Figure 2 - Installation of plastic anchors

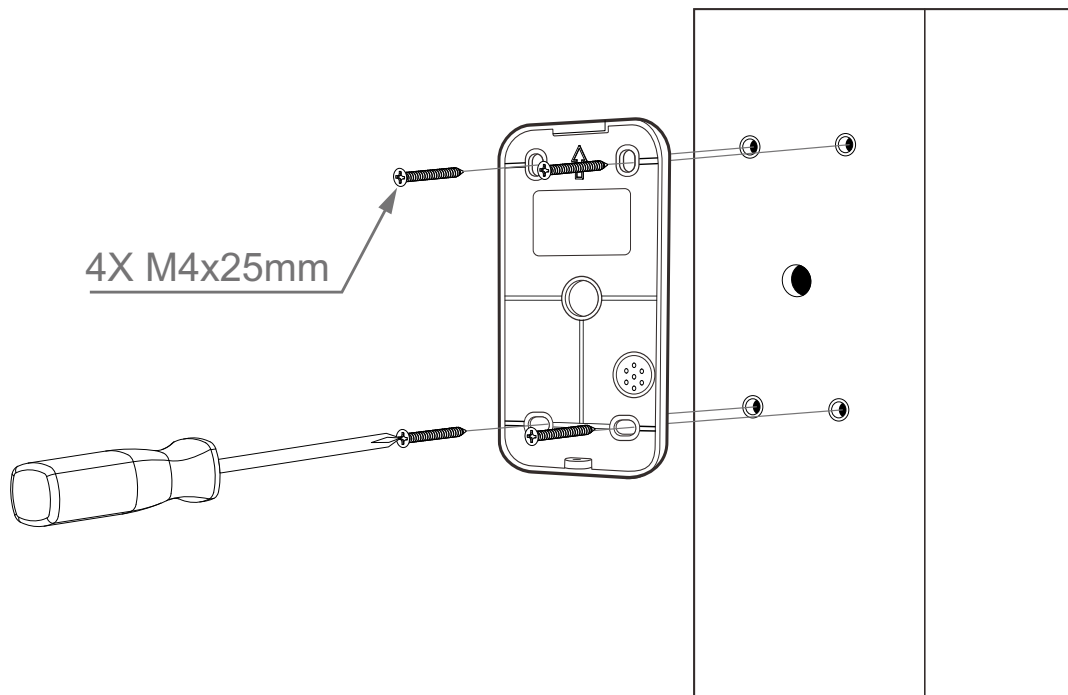

Figure 3 - Installation of Mounting Hardware

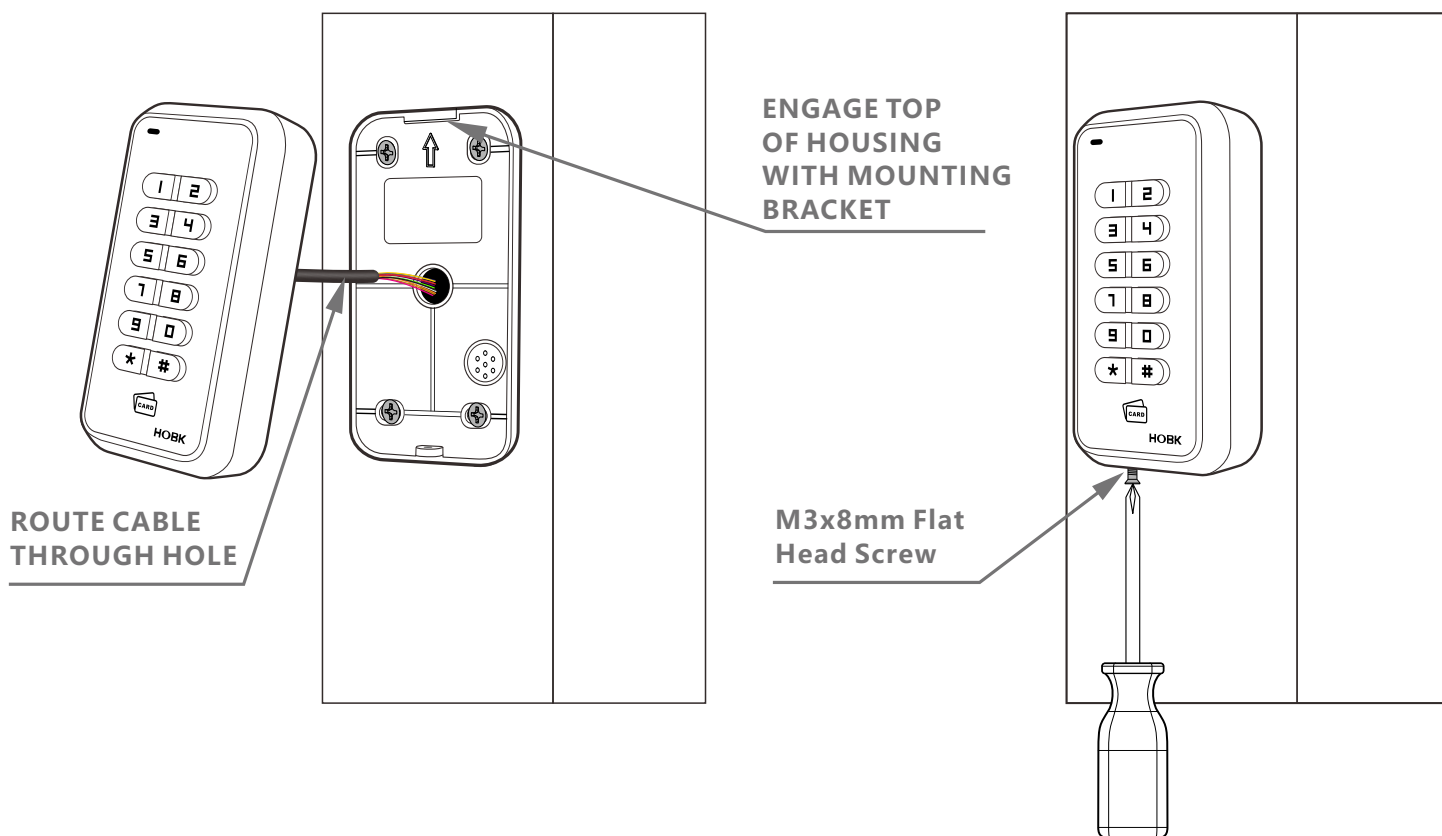
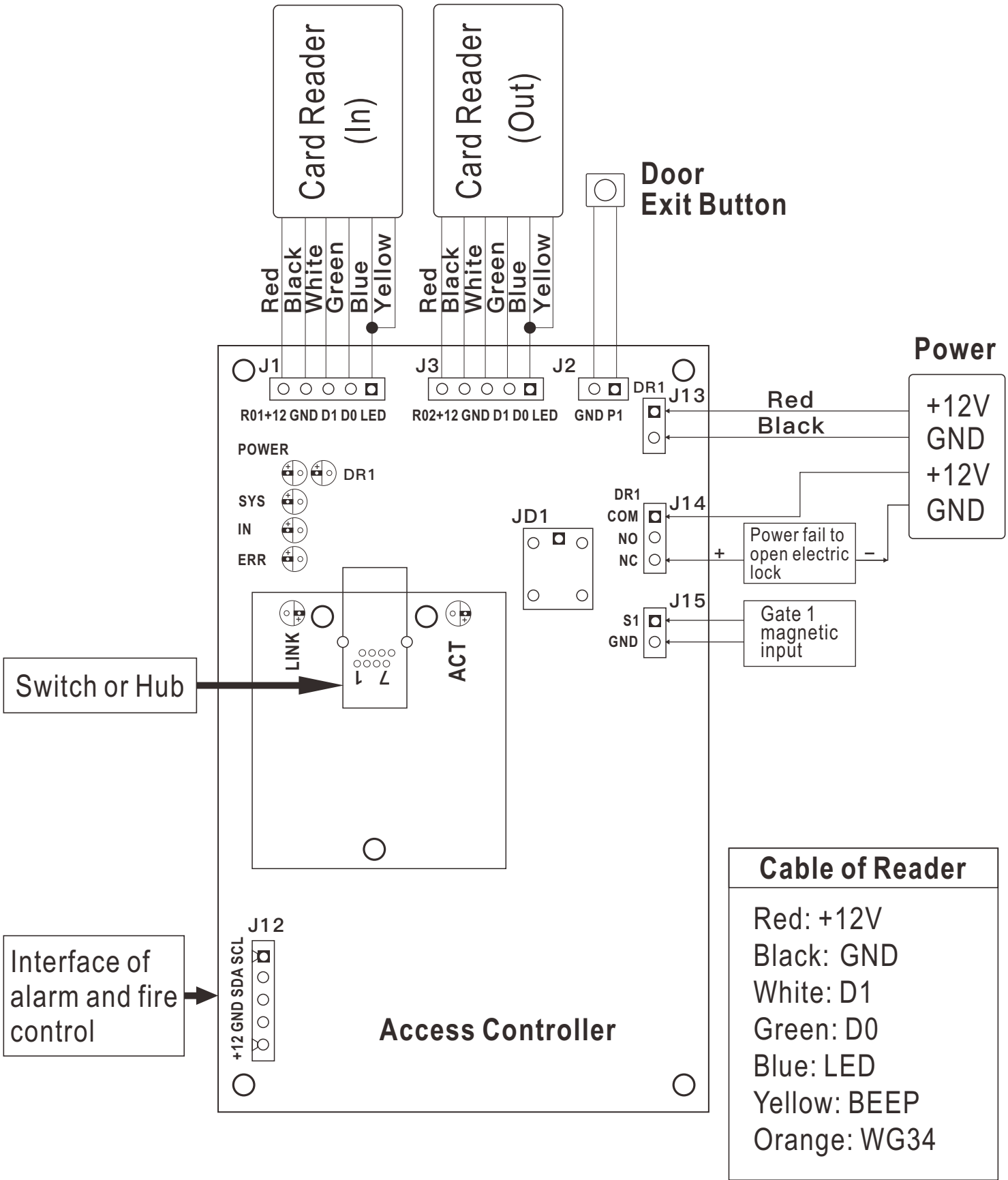

Figure 4 - Installation of HBK-D04K

Figure 5 - Installation of securing screw

Wiring Diagram



Sound and Light Indication

Operation Status	LED Indicator	Sound
Standby	Red	
Read authorized card	Green	A short beep
Read un-authorized card	Flash red 3 times	3 short beeps

Remarks: The card reader will prompt sound and light indication only when the LED and BEEP cables are connected to the access controller.

Warm Tips

- Confirm the voltage (12VDC) and differentiate positive anode and cathode of the power supply.
- About the wiring between the reader and the controller, the wire should be 22 AWG at least and the length should not exceed 100 meters.
- When external power is used, suggest to use same power GND with controller panel. It is recommended to use multi-strand twisted pair cable to connect card reader to access controller.
- There is no need to wire the LED and BEEP cables if you do not need the card reader to prompt an authorized card through sound and light.

Packing List

Name	Quantity	Remarks
Card Reader	1	
User Manual	1	
Plastic Anchors	4	Φ6x25mm, used for fixing
Self-Tapping Screw	4	M4x25mm Philips Self Tapping Screw

Packing Details

After opening the package, please make sure the device is in good condition and confirm below accessories are complete or not.

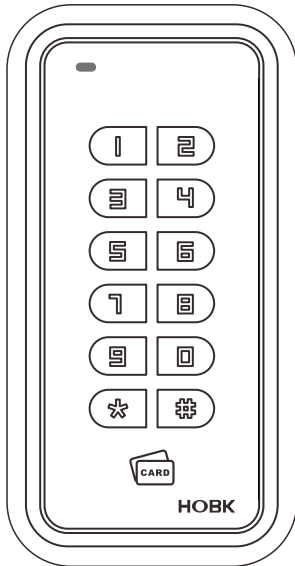

HBK-D04K x1

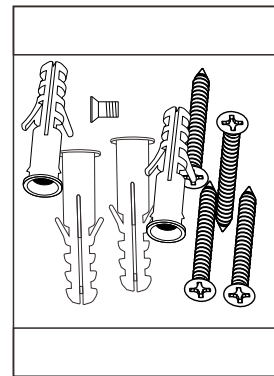

Accessories Package x1

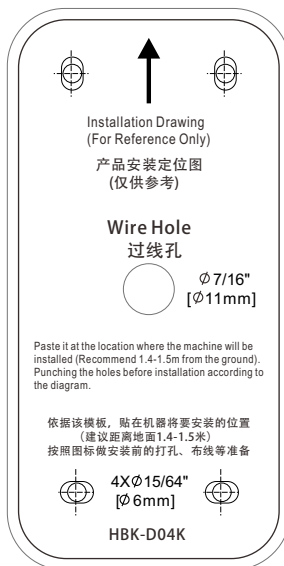

Installation Drawing x1

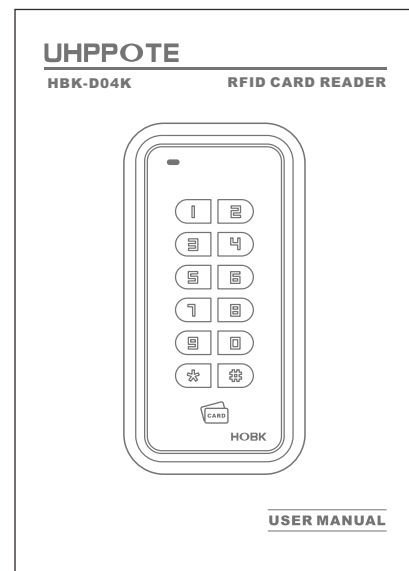

User Manual x1

FCC Warning

FCC ID: 2A4H6HBK-D01

This device complies with part 15 of the FCC Rules. Operation is subject to the following two conditions: (1) this device may not cause harmful interference, and (2) this device must accept any interference received, including interference that may cause undesired operation. Any changes or modifications not expressly approved by the party responsible for compliance could void the user's authority to operate the equipment.

NOTE: This equipment has been tested and found to comply with the limits for a Class B digital device, pursuant to Part 15 of the FCC Rules. These limits are designed to provide reasonable protection against harmful interference in a residential installation. This equipment generates, uses and can radiate radio frequency energy and, if not installed and used in accordance with the instructions, may cause harmful interference to radio communications. However, there is no guarantee that interference will not occur in a particular installation. If this equipment does cause harmful interference to radio or television reception, which can be determined by turning the equipment off and on, the user is encouraged to try to correct the interference by one or more of the following measures:

- Reorient or relocate the receiving antenna.
- Increase the separation between the equipment and receiver.
- Connect the equipment into an outlet on a circuit different from that to which the receiver is connected.
- Consult the dealer or an experienced radio/TV technician for help. To maintain compliance with FCC's RF Exposure guidelines, This equipment should be installed and operated with minimum distance between 20cm the radiator your body: Use only the supplied antenna.

UHPPOTE

© 2024 HOBK Electronic Technology Co., Ltd All rights reserved



>75% recycled paper

Produced By HOBK